

WORLD SERIES®

INDUCTION MOTORS & GENERATORS



TECO   **Westinghouse**



WORLD SERIES® MOTORS



TECO-Westinghouse North American Headquarters in Round Rock, Texas, USA

A Proud Tradition of Leadership

Westinghouse began a longstanding tradition of industry leadership in 1894, when company founder George Westinghouse introduced the world's first line of commercially practical polyphase motors — our venerable Type B induction motors. Since that pioneering achievement, which launched a new era in the utilization of electrical energy, we have continued to lead the way. Responding through the years to the growing demands of industry, we have developed several generations of large-scale induction motors, each setting new standards for performance and reliability. These advances culminated with the World Series® family of motors, which marks the high point in the evolution of large electric motors.

A Distinguished Record of Innovation

TECO-Westinghouse Motor Company's position as a world leader in the design and manufacture of large induction motors is secured by an unflinching commitment to engineering excellence and technological innovation. Among our most notable pacesetter advances are the Thermalastic® Epoxy Insulation system, refinements in copper bar rotor construction, and our Pole Amplitude Modulation (PAM) motors. Much of our successful innovation derives from our emphasis on computer-aided design as a tool for engineering excellence. Drawing on many decades of design related computer programming and analysis, we optimize the design of every motor for the highest operating efficiency. These experience-based computer capabilities account for the high levels of performance and refinement that characterize the World Series® induction motors.

Geared to the Needs of Heavy Industry

Built to address the most power intensive requirements of heavy industry, World Series® motors are the largest induction motors in the **TECO-Westinghouse Motor Company** product line.

Scope and Range

The World Series® line includes horizontal and vertical squirrel cage induction motors ranging from 250 hp to 30,000 hp, and from 460 V to 13,800 V. They are available in both 50 Hz and 60 Hz frequencies, as well as adjustable frequencies. The line also includes Pole Amplitude Modulation (PAM) motors, an area of electric motor technology in which **TECO-Westinghouse** is the acknowledged world leader.



WORLD-CLASS PERFORMANCE

Whether your application requires a 250 horsepower motor, a 30,000 horsepower motor, or anything in between, look to World Series® motors for the utmost in value and performance.

World Series® motors are a top-quality line of induction motors that are distinguished by higher efficiencies, advanced software design capabilities, metric frame sizes and **TECO-Westinghouse's** reputation for quality and reliability.

INDUCTION MOTOR CAPABILITY

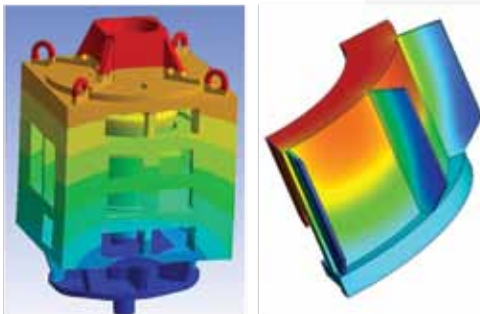
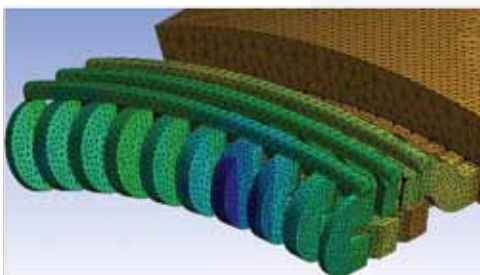
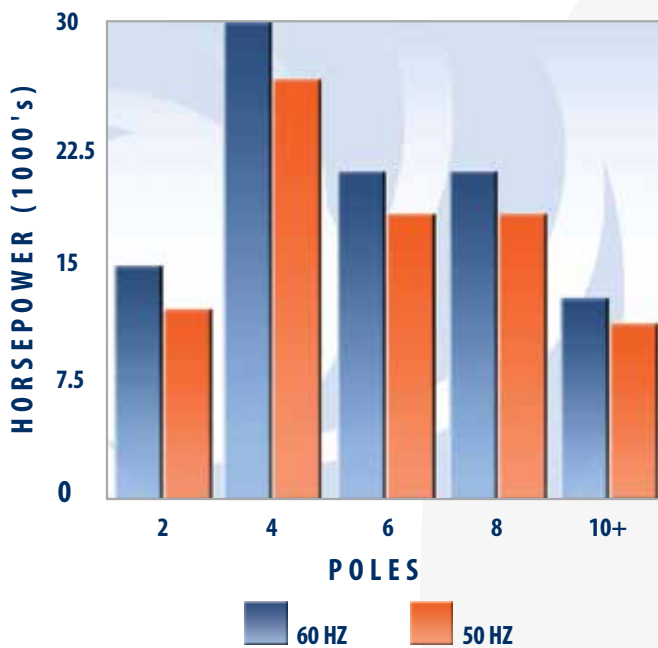

ENHANCED EFFICIENCIES FOR GREATER SAVINGS

Operating efficiencies are vitally important to the bottom line needs of industry. You can save hundreds of thousand of dollars over the life of a motor by careful evaluation of the operating efficiency. For this reason, World Series® motors are designed to deliver operating efficiencies that are among the highest in the world.

The following key features have enabled World Series® motors to reduce operating losses up to 30 percent from previous designs:

Powerful Computer Design Programs

Using sophisticated computer aided design programs, **TECO-Westinghouse** engineers study your electrical and mechanical specifications, scan hundreds of design possibilities in minutes, and select the best design for your specific requirements. The result: each motor design is optimized for the highest operating efficiency.

Headquartered in Round Rock, Texas, USA, our Global Design Center has state-of-the-art software capabilities to allow us to respond more quickly to your needs with complete quotations and accurate motor performance data. Computer-aided design and drafting programs are utilized to produce accurate outline drawings showing the selected motor design envelope. Three dimensional (3D) solid models are created for specific designs to insure that accurate information is provided.

During the design phase of the motors, finite element analysis programs are available for calculating the lateral natural frequency of the rotor and bearing system and for stress and strain analysis.

Metric Frames Sizes

World Series® motors are built on a metric family of frame sizes that conform to IEC standards. As a result, a wider range of frame sizes are available, allowing our engineers to select optimized designs for any horsepower, RPM or voltage rating with no gaps in the entire product line. Our breadth of frame sizes also enables more efficient ventilation, which helps reduce heating and windage losses.

Improved Materials

World Series® motors incorporate the latest advances in insulation materials. Superior insulating materials allow increased use of copper in the electrical circuit, which enhances operating efficiency.

WORLD SERIES® FEATURES

Thermalastic® Insulation System for Unequalled Dielectric Strength and Voltage Endurance

Thermalastic® is a proprietary integrated insulation system that impregnates the wound and connected stator with a solventless epoxy resin. Originally developed by **Westinghouse** over 60 years ago, Thermalastic® is acknowledged as the industry's premier insulation system and is under continuous development to maintain its position as the world's finest.

Mica is the heart of the Thermalastic® insulation system and is applied to the groundwall section of all of the stator coils. The form-wound stator is post-impregnated with epoxy resin in a vacuum pressure tank and then transferred to an oven for polymerization. The result is a stator insulation system that withstands prolonged voltage stresses, moisture, dirt, thermal cycling and chemical contaminants.

For ratings 6 kV and above, a semi-conducting layer is applied to the slot section. Gradient tape is applied beyond the core at 7 kV for corona suppression. Designs are also available up to 13.8 kV.



Advanced Bearing System for Reliable Performance

The bearing system used in World Series® motors has been designed and engineered for continuous, reliable performance and easy maintenance. Both anti-friction and split-sleeve bearings are offered. When required, insulation can be added to either bearing type.

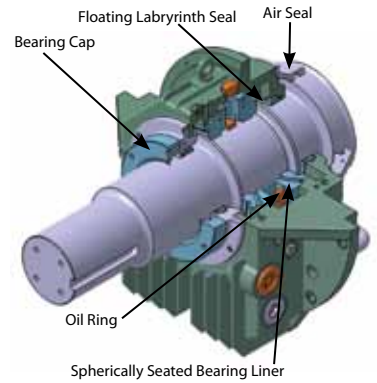

Our split-sleeve bearings are spherically seated and self aligning, thus easy to service in all field conditions. They also feature a high-tin content babbitt material and a heavy-duty, two-piece bronze oil ring. The oil ring lubrication process is easily modified for flood lubrication.

This bearing unit employs a sophisticated sealing system that is designed to prevent oil leakage along the shaft. An optional buffered seal can be provided when pressurization is required to prevent hostile environments from entering the bearing.

The bearings can be inspected visually through an oil ring sight gauge and an oil level sight gauge on the housing. Bearing caps can be easily removed for bearing inspection without uncoupling the motor from the driven machine. No special tools are required for the inspection procedure.

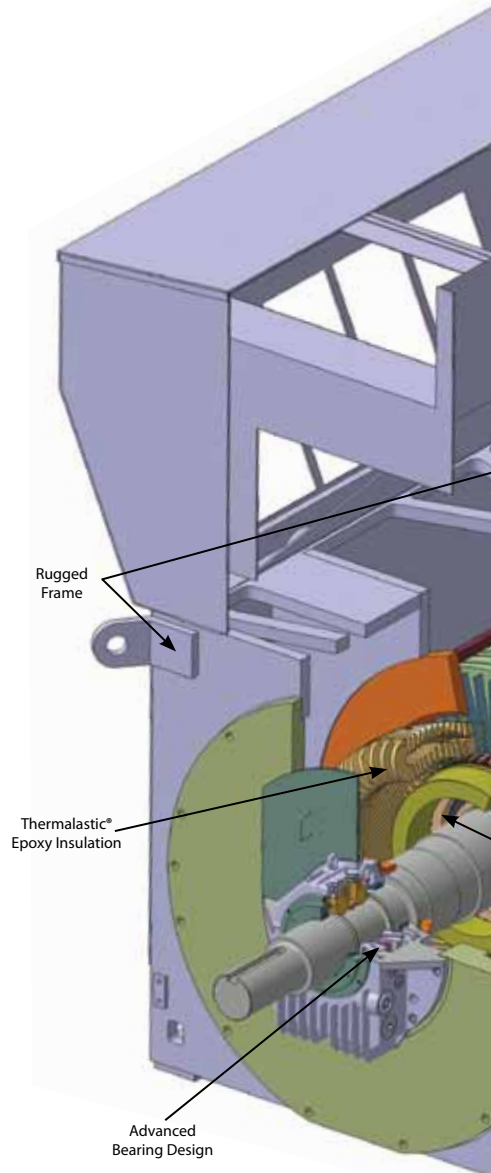

Rugged Box Frame Construction for Strength and Reliability

World Series® motors use box frame construction to provide frames that have the mechanical strength and stability to assure years of dependable, economical performance.

The fabricated steel frames are braced by heavy steel plate bulkheads and end plates to make the frames both laterally and torsionally stable. End brackets are reinforced to give the bearings rigid support and to minimize vibration. Located in line with the end of the frame, the bearing housing provides maximum bearing stiffness. Overall frame strength also minimizes vibration and virtually eliminates the need for realignment.

A wide range of frame sizes is available for the utmost in design flexibility at any motor rating.

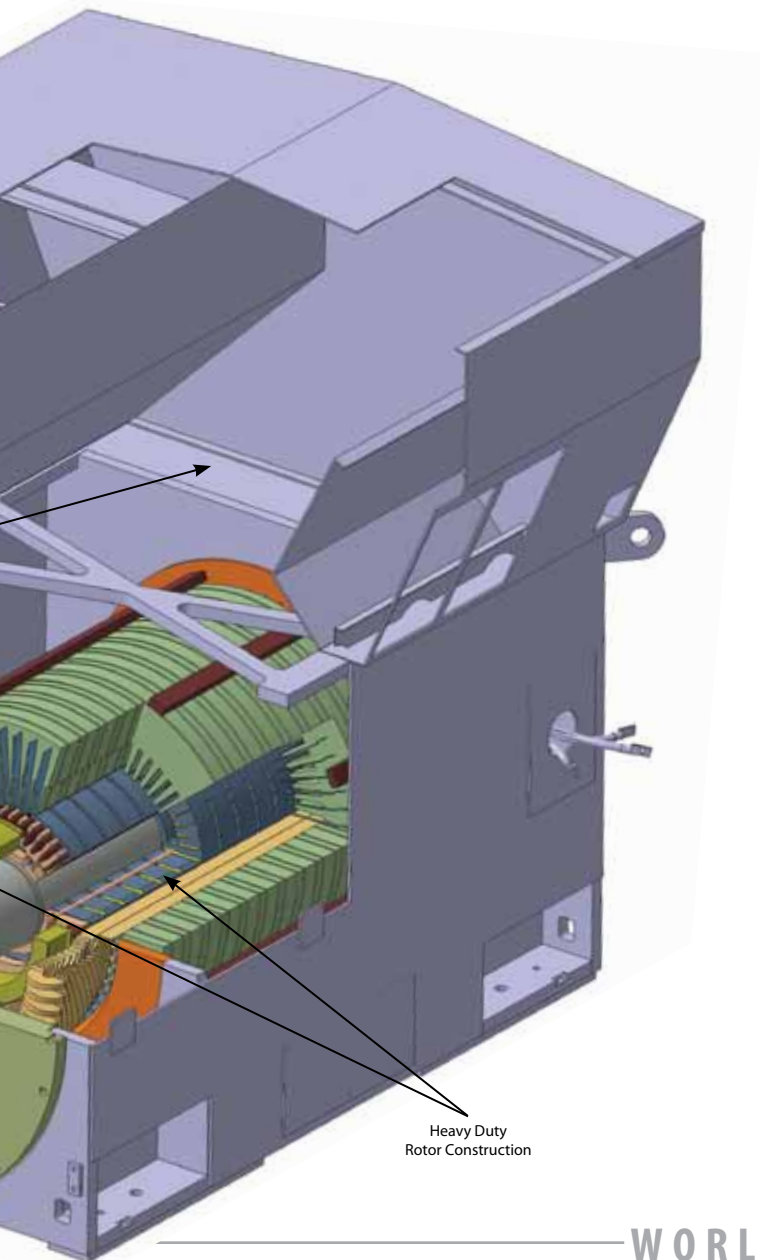

Heavy-Duty Rotor Construction for Dependable Service

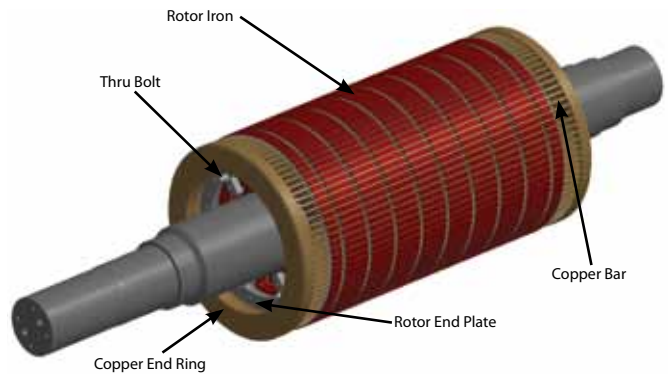

TECO-Westinghouse induction motor rotors are recognized as the most reliable in the industry, and their high performance standards are a hallmark of the World Series® motors.

Each lamination is coated with C5 insulation, which provides interlaminar resistance. Core losses will be minimized because the C5 coating will not degrade at any operating temperature or co-react with other insulating materials, varnishes or paints.

Rotor cores are held together by a unique system of heavy-duty through-bolts and end plates. Core mechanical integrity does not rely on any electrically active component. Rotor bars and end rings are copper or copper alloy. Copper is the time-proven choice for rotor construction because it provides maximum performance and reliability.

Swaged rotor bars ensure long motor life by minimizing the movement and vibration that can cause bar fatigue and failure. End rings are manufactured for a void-free cross section and purity, and they are joined to the bars by brazing to reduce stresses and hot spots in the joint, which can cause fatigue and failure.

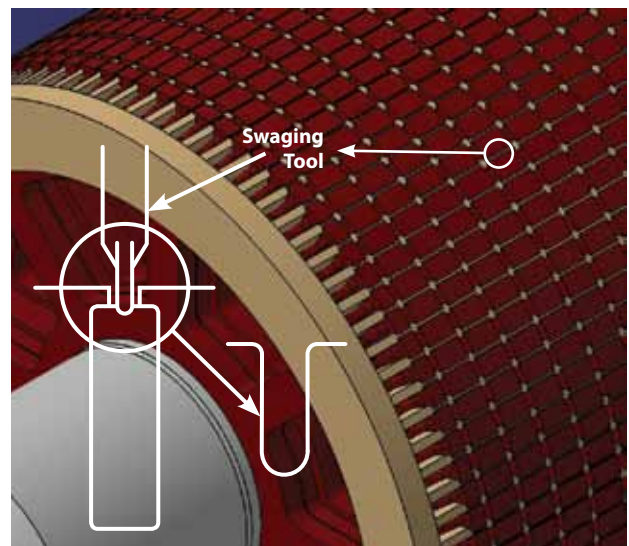

Available Cooling Enclosures

World Series® motors are offered in a complete range of cooling enclosures to meet the toughest demands of industry. Designs are available in NEMA or IEC standards. Available cooling enclosures include the following configurations:

- Open Drip-Proof Guarded, IP22/ IC01

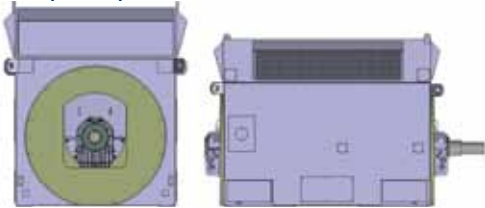

- Weather-Protected Type I, IP23/ IC01 & Weather-Protected Type II, IPW24/ IC01

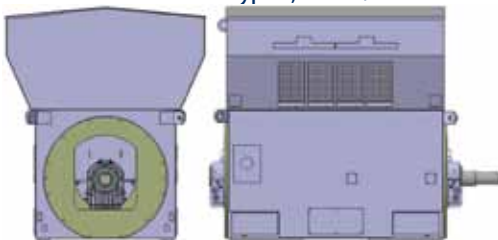

- Totally-Enclosed Water-to-Air-Cooled, IP44-54/ ICW81

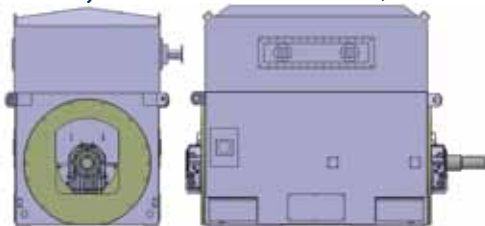

- Totally-Enclosed Air-to-Air -Cooled, IP44-54/ IC611 or IC616

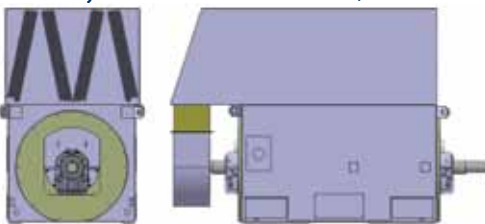

- Totally-Enclosed Pipe-Ventilated, IP44/ IC31 or IC37

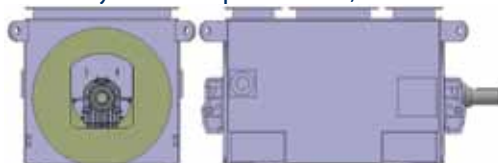

Terminal Boxes

World Series® motors feature main lead terminal boxes constructed of 11-gauge steel. Each terminal box is gasketed for air-tight, dust-free and weather-proof protection of terminal leads. Available for F1 or F2 locations, terminal boxes can be modified to include any customer terminations and accessory devices.

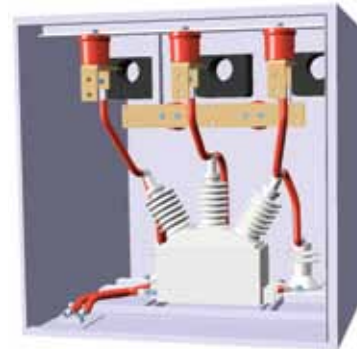

Main Terminal Box with Optional Accessories

The main lead terminal box provides termination of the motor’s main power leads. Available terminal box options include lightning arresters, surge capacitors, current transformers, special grounding devices, partial discharge monitoring equipment, cable or bus bar terminations, and top, bottom, or side lead entry. Main lead terminal boxes can range from 14 x 13 x 18 inches (355 x 330 x 450 millimeters) up to 48 x 54 x 66 inches (1200 x 1370 x 1670 millimeters), or customized to meet any specific requirements.

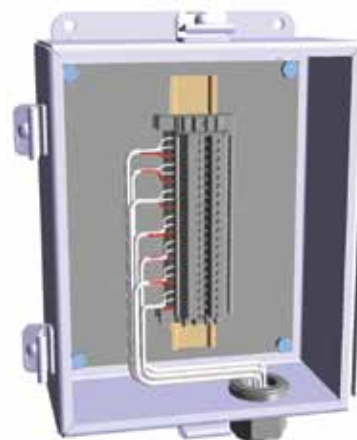

Auxiliary Terminal Box

APPLICATIONS

World Series® motors are custom-designed to each customer's specific application. Because of their design versatility and high operating efficiencies, the World Series® motors are the logical choice for a multitude of industries, including pulp and paper, electric utility, marine, water and waste water treatment, chemical and petrochemical, steel, mining, air conditioning, cement, and air separation applications. World Series® motors are used on fans, pumps, compressors, crushers, extruders, conveyors, and most types of variable and constant torque process equipment. They also can be used as induction generators for energy recovery.

World Series® motors can be designed to do almost any big job imaginable - in almost any environmental condition. They also are available in the following special design configurations:

Pole Amplitude Modulation (PAM) Motors

World Series® motors can be designed to operate as two-speed, one-winding Pole Amplitude Modulation (PAM) motors. PAM motors offer the flexibility and energy savings of two speeds while requiring only one winding. **TECO-Westinghouse** is the world leader in PAM motors, offering more experience than all other motor manufacturers combined.

Adjustable Frequency

Our motors can be engineered to operate with many of today's most advanced adjustable frequency drives. These drives adjust the motor's speed by changing the frequency of the power feeding the motor. By utilizing these drives, users can save energy, better handle high inertia loads, and improve overall reliability. If you are considering a VFD application, then pair your drive with a quality World Series® motor.

Vertical Motors

TECO-Westinghouse has had a long and successful history with vertical motor applications. Used primarily for pump applications, vertical motors are designed to handle virtually any thrust load that might be imposed (including loads well in excess of 1,000,000 lbs. continuous down-ward thrust). High-thrust load capability can be achieved by utilizing hydrodynamic-type tilting-pad thrust bearings. Both sleeve and ball bearings are available for guide bearings, depending on the application.

For long wear and reliability, the thrust bearings and guide bearings are air-cooled through constant ventilation and also oil-lubricated from a large reservoir. Water-cooling coils can also be added when needed.

World Series® vertical motors reflect the same high quality construction and insulation processes that distinguish all the various components of our horizontal motors. Our vertical motors are readily adaptable to a variety of specific needs. For example, non-reverse ratchets are available and flywheels can be included in the design when required. Our vertical motors can also be started from zero speed or reverse speed and can be designed to accommodate overspeed situations, as in a hydro-generator.

Replacement Motors

In today's market, replacement or interchangeable motors are essential to keeping your operations running. If you are in need of a spare motor or are considering whether to repair or replace an existing machine, **TECO-Westinghouse** has extensive experience in retrofitting **Westinghouse** legacy motors or other motor OEM dimensions. Motor foundation dimensions, customer conduit entries, and key electrical parameters can generally be retrofitted if the information is known. The next time you need to replace a machine, contact **TECO-Westinghouse** to see how we can help.



World Series® Motor Dimensions

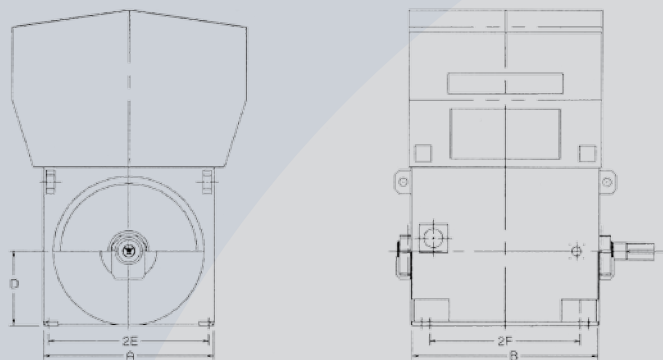

WORLD SERIES® MOTORS: SETTING THE STANDARD OF EXCELLENCE

World Series® motors integrate the best of new motor technologies, such as computer design and advanced materials, with the best of proven technologies, including rugged copper rotor construction, Thermalastic® epoxy insulation and strong box frames. This unique blend of new and traditional features makes the World Series® motors the optimal choice for heavy industry applications anywhere in the world.

Each World Series® motor is backed by over 100 years of **TECO-Westinghouse** design experience and industry leadership, as well as the expertise of **TECO-Westinghouse's** worldwide field service and engineering network to service and protect your investment.

Discover how the efficiencies and economies of World Series® Motors can work for you. Contact your local **TECO-Westinghouse** representative or call toll free: **1-800-451-8798**.

FRAME	POLES	EST. WT. (lbs)	DIMS. (inches)				
			D	2E	A	2F	B
3505	4P UP	3200	13.98	28.0	31.3	22.0	32.9
3506	2P	3500	13.98	28.0	31.3	24.8	35.6
3507	4P UP	3800	13.98	28.0	31.3	28.0	38.8
3508	2P	4000	13.98	28.0	31.3	31.5	42.3
3509	4P UP	4300	13.98	28.0	31.3	35.4	46.3
3510	2P	4700	13.98	28.0	31.3	39.4	50.2
4008	4P UP	4800	15.75	31.5	35.2	31.5	42.3
4009	2P	5100	15.75	31.5	35.2	35.4	46.5
4010	4P UP	5500	15.75	31.5	35.2	39.4	50.2
4011	2P	5900	15.75	31.5	35.2	44.1	54.9
4509	4P UP	7500	17.72	35.4	39.1	35.4	50.2
4510	2P	7800	17.72	35.4	39.1	39.4	53.9
4511	4P UP	8000	17.72	35.4	39.1	44.1	58.9
4512	2P	8700	17.72	35.4	39.1	49.2	63.7
5010	4P UP	9600	19.68	39.4	43.9	39.4	53.9
5011	2P	10,500	19.68	39.4	43.9	44.1	58.4
5012	4P UP	10,500	19.68	39.4	43.9	49.2	63.7
5014	2P	11,000	19.68	39.4	43.9	55.1	69.4
5611	4P UP	14,000	22.05	46.5	49.0	44.1	58.6
5612	2P	14,500	22.05	46.5	49.0	49.2	63.2
5614	4P UP	15,000	22.05	46.5	49.0	55.1	69.6
5616	2P	17,000	22.05	46.5	49.0	63.0	77.0
6312	2P UP	18,000	24.8	49.2	55.9	49.2	67.9
6314	2P UP	18,500	24.8	49.2	55.9	55.1	74.8
6316	2P UP	19,000	24.8	49.2	55.9	63.0	81.7
6318	2P UP	20,000	24.8	49.2	55.9	70.9	89.1
7112	2P UP	21,000	27.9	55.1	59.1	49.2	65.0
7114	2P UP	22,000	27.9	55.1	59.1	55.1	70.9
7116	2P UP	23,000	27.9	55.1	59.1	63.0	78.7
7118	2P UP	24,000	27.9	55.1	59.1	70.9	86.6
8014	4P UP	26,500	31.5	66.9	71.0	55.1	70.9
8016	4P UP	28,000	31.5	66.9	71.0	63.0	78.7
8018	4P UP	29,500	31.5	66.9	71.0	70.9	86.6
8020	4P UP	31,000	31.5	66.9	71.0	78.7	94.5



5100 N. IH-35
Round Rock, Texas 78681
1-800-451-8798

www.tecowestinghouse.com